



US 20140322852A1

(19) **United States**

(12) **Patent Application Publication**
JOO et al.

(10) **Pub. No.: US 2014/0322852 A1**

(43) **Pub. Date: Oct. 30, 2014**

(54) **DEPOSITION APPARATUS AND METHOD OF MANUFACTURING ORGANIC LIGHT EMITTING DIODE DISPLAY**

(52) **U.S. Cl.**
CPC *H01L 51/0012* (2013.01)
USPC **438/46; 118/500**

(71) Applicant: **Samsung Display Co., Ltd.**,
Yongin-City (KR)

(57) **ABSTRACT**

(72) Inventors: **Sung-Joong JOO**, Yongin-City (KR);
You-Min CHA, Yongin-City (KR);
Seuk-Hwan PARK, Yongin-City (KR)

(73) Assignee: **Samsung Display Co., Ltd.**,
Yongin-City (KR)

A deposition apparatus includes a deposition chamber, a plurality of substrate holders comprising a first holder configured to maintain a substrate at a first substrate position in the deposition chamber and a second holder configured to maintain another substrate at a second substrate position in the deposition chamber, a deposition source disposed in the deposition chamber and configured to supply a deposition material to apply onto substrates placed at the first and second substrate positions, and a deposition source transfer mechanism configured to move the deposition source to be opposite to one of the first and second substrates in a first direction, a substrate transfer mechanism configured to transfer a substrate in a second direction to or from the first substrate position and further configured to transfer another substrate in the second direction to or from the second substrate position.

(21) Appl. No.: **14/074,629**

(22) Filed: **Nov. 7, 2013**

(30) **Foreign Application Priority Data**

Apr. 26, 2013 (KR) 10-2013-0046775

Publication Classification

(51) **Int. Cl.**
H01L 51/00 (2006.01)

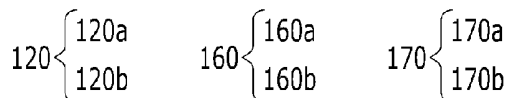
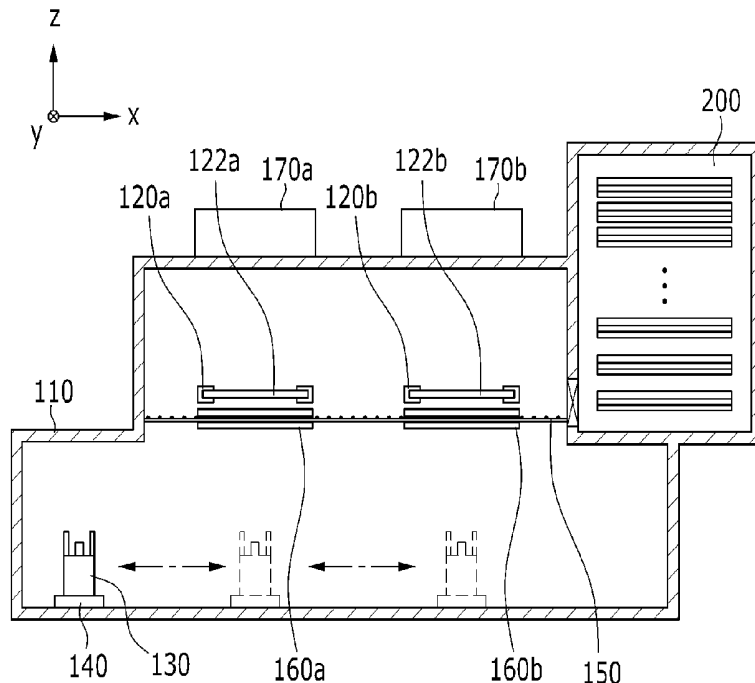

FIG. 1

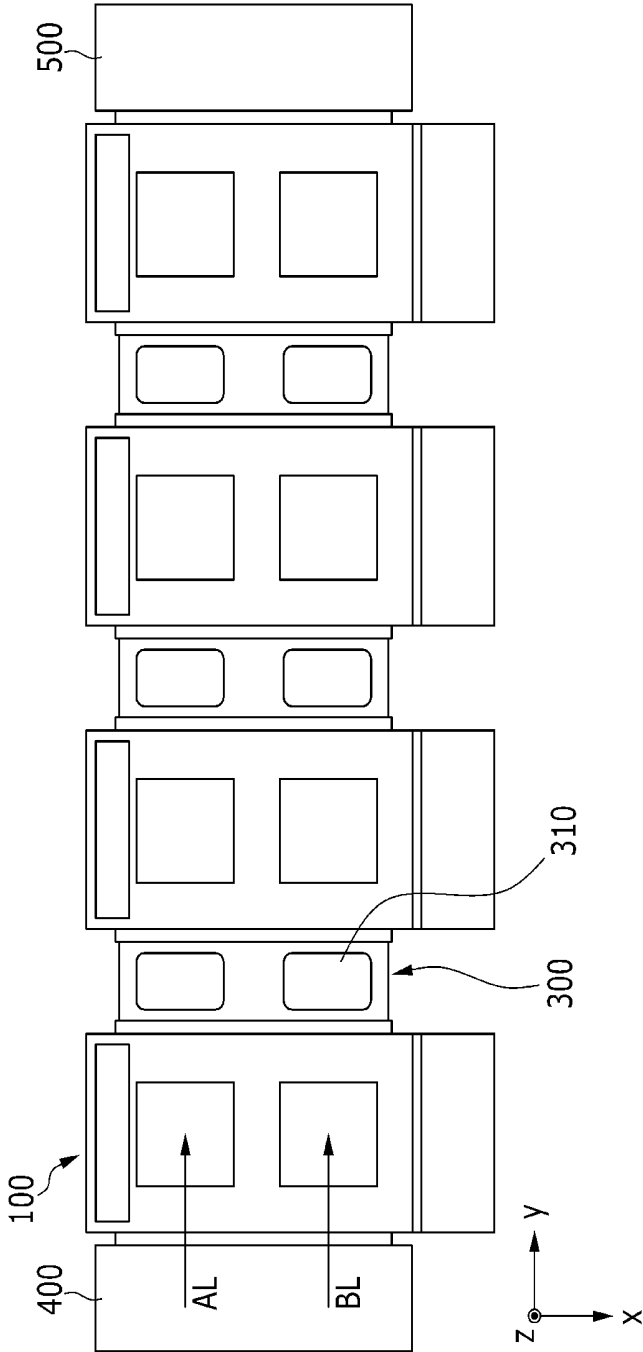
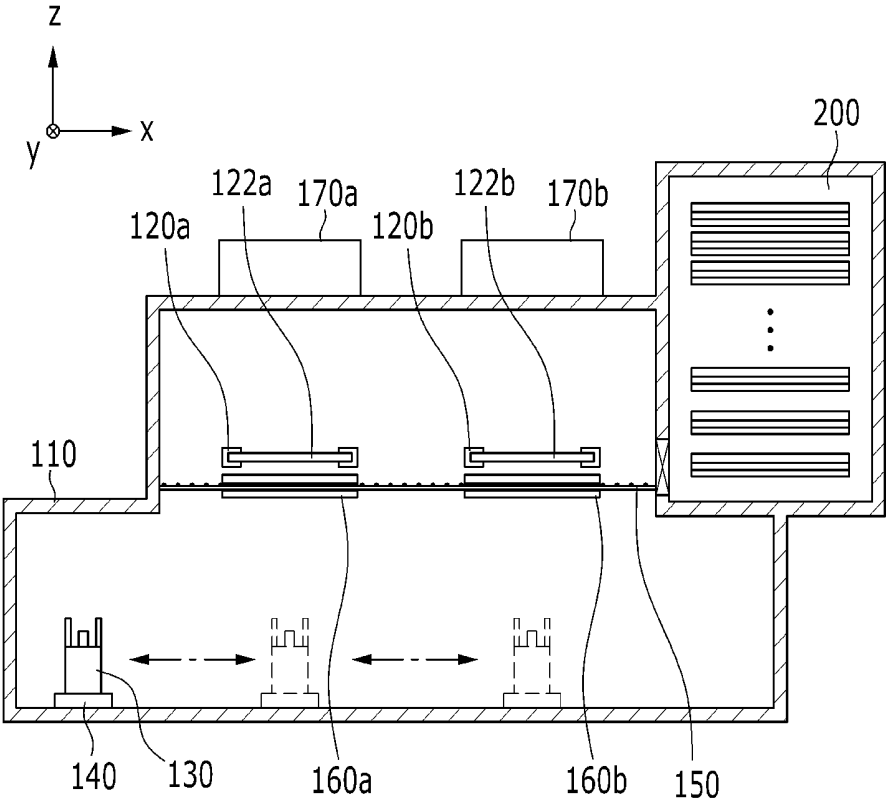

FIG. 2



120 { 120a
120b

160 { 160a
160b

170 { 170a
170b

FIG. 3

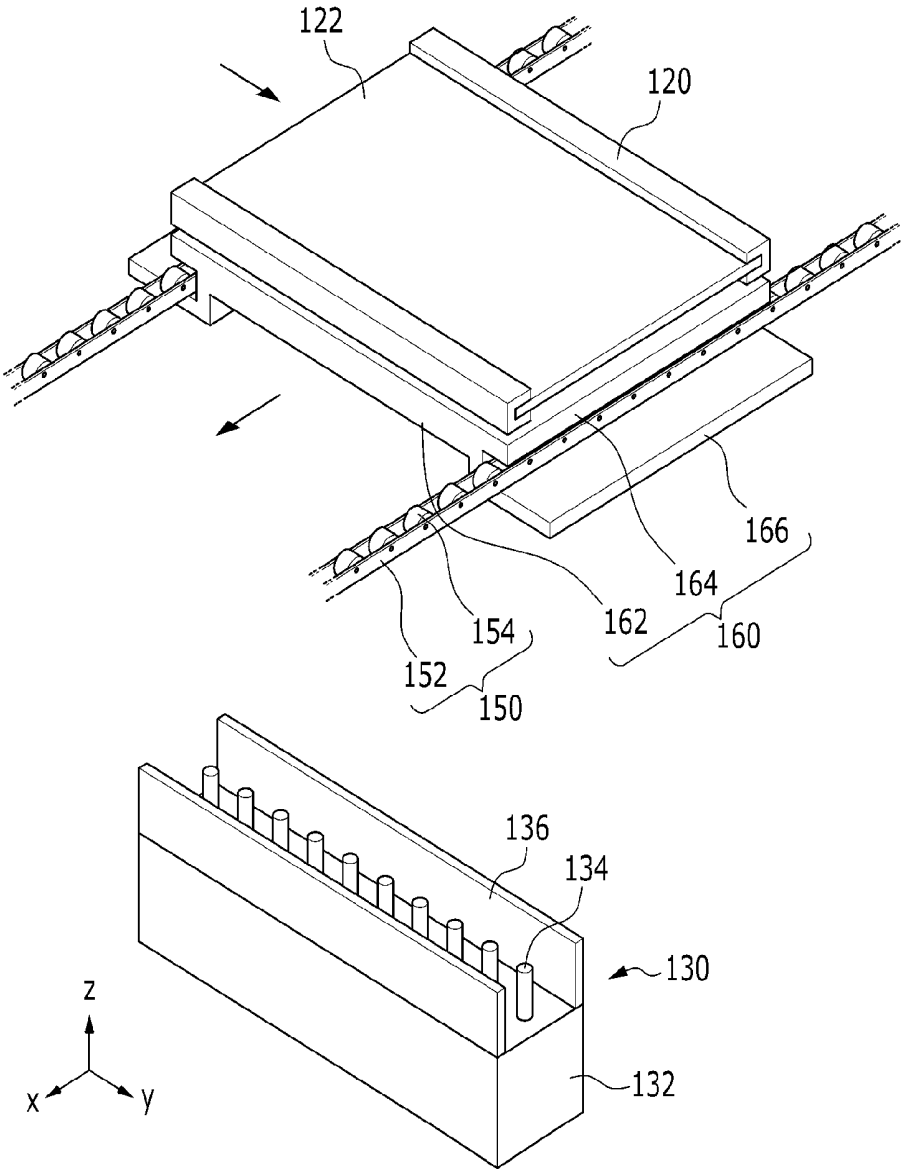

FIG. 4

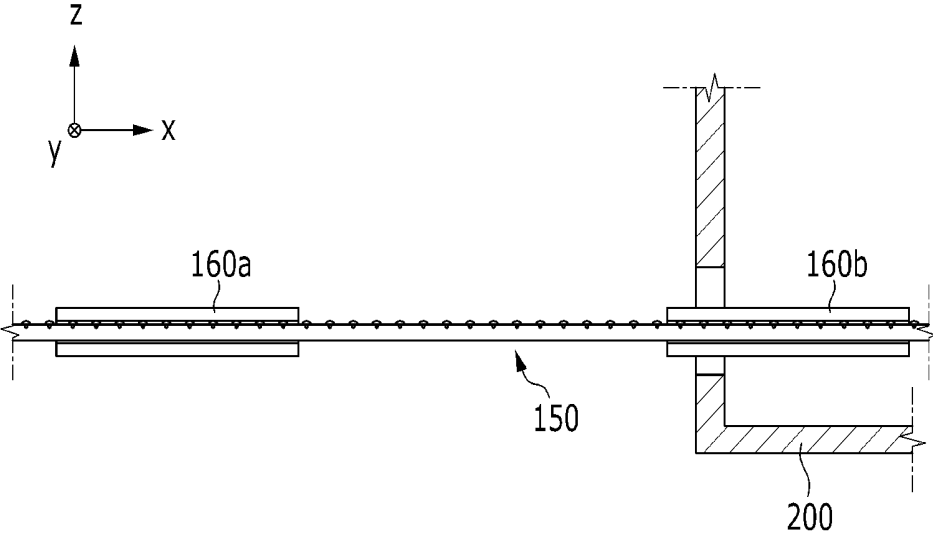

FIG. 5

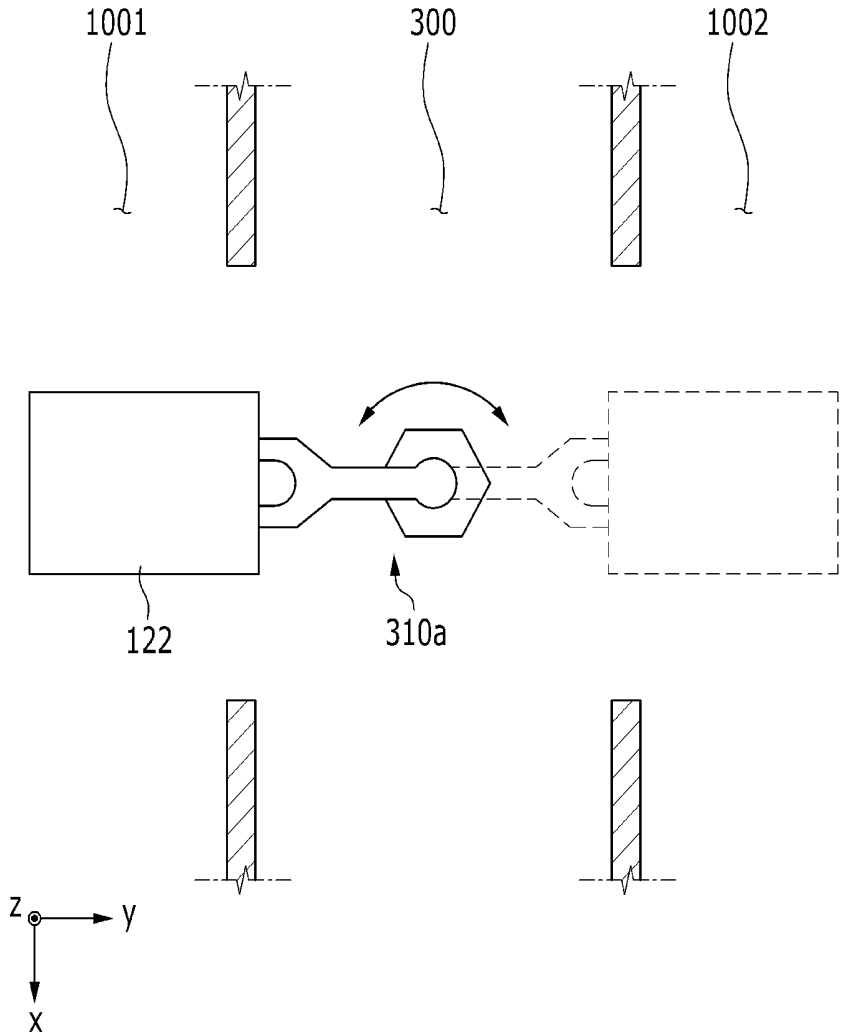

FIG. 6

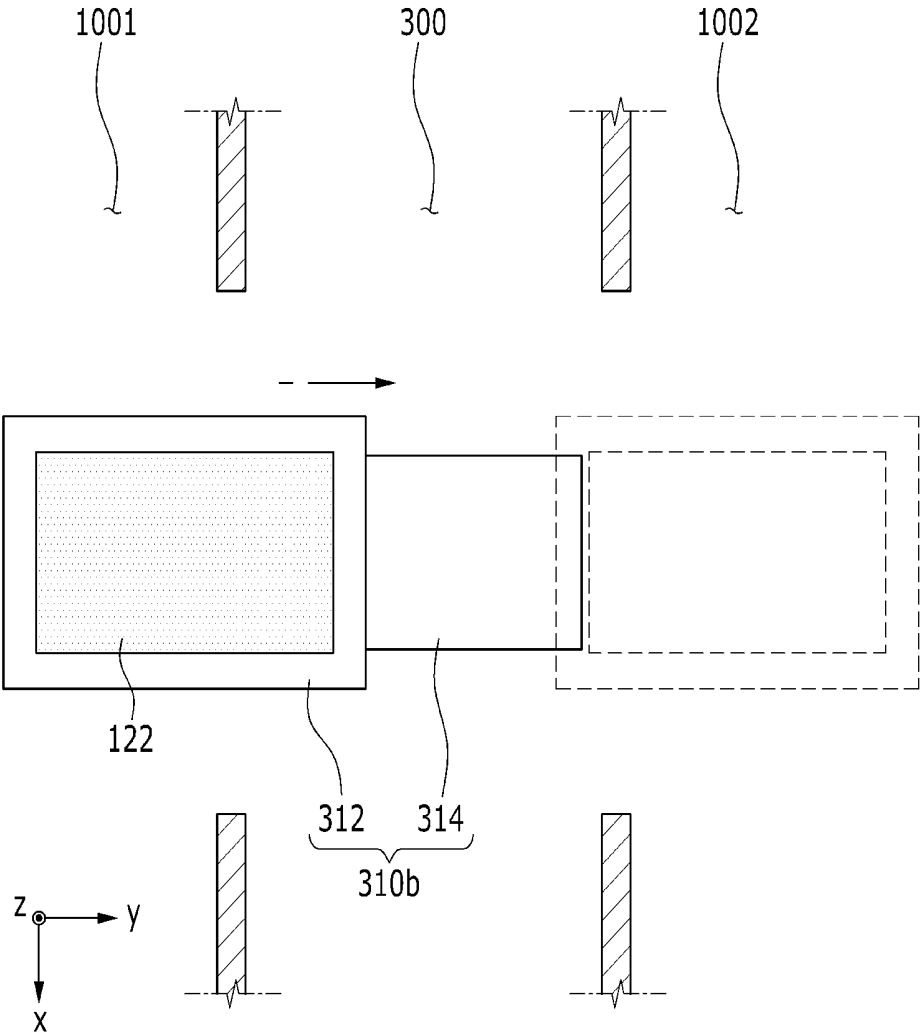

FIG. 7

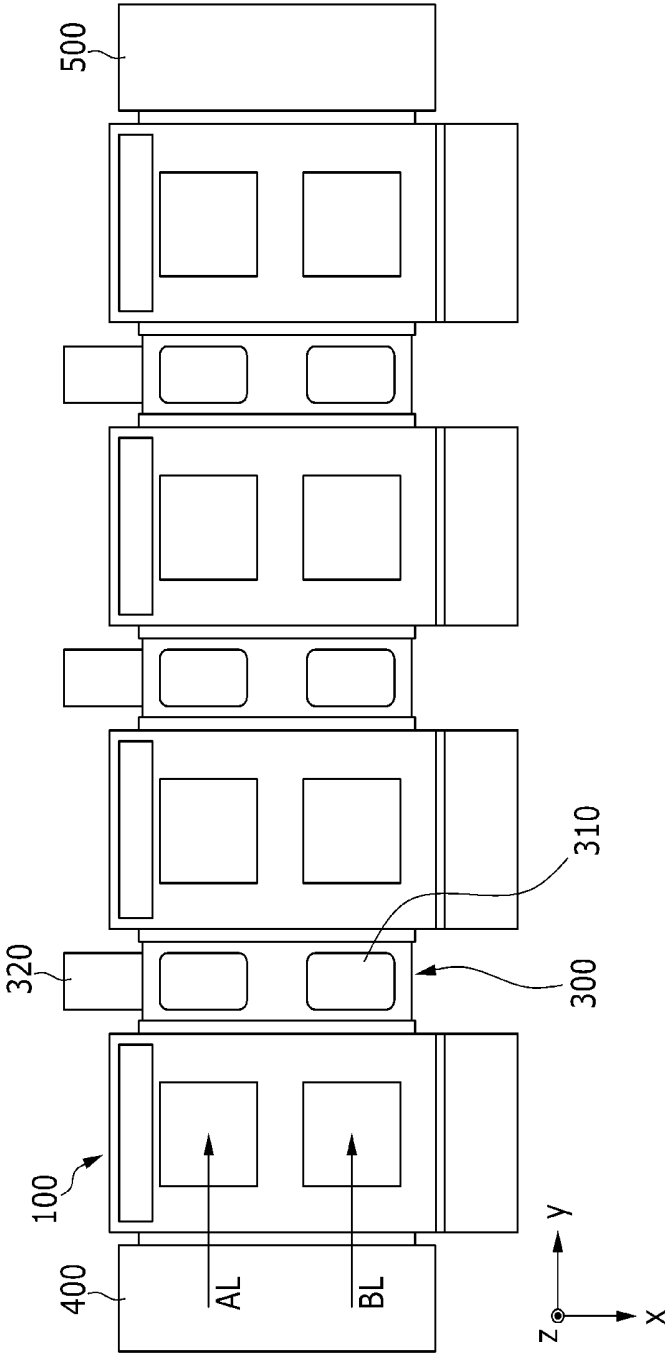
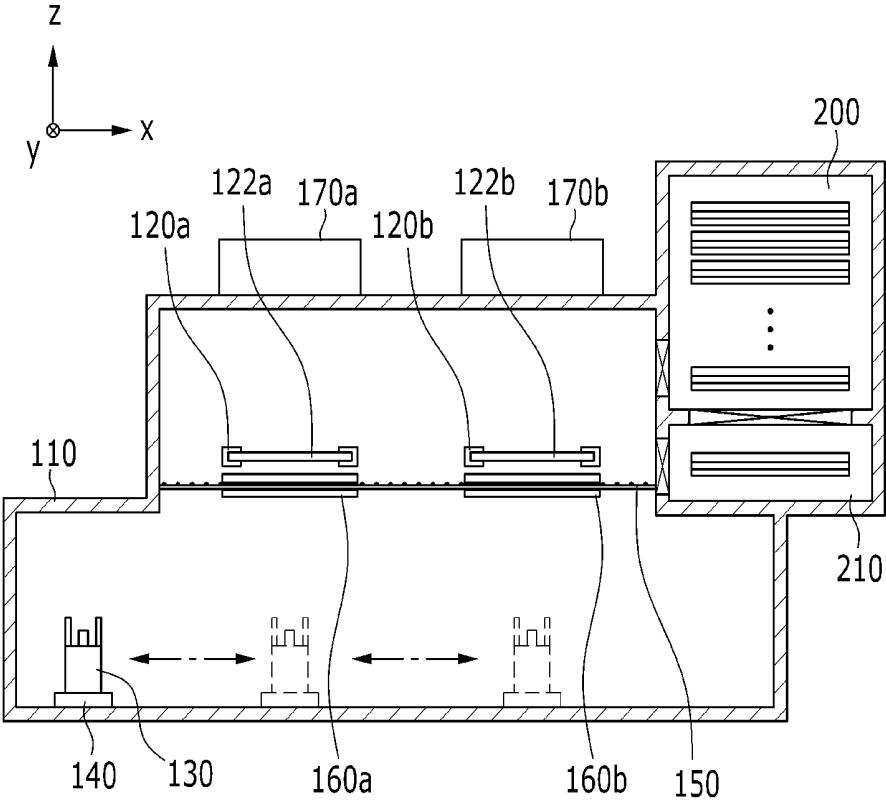

FIG. 8



120 { 120a
120b

160 { 160a
160b

170 { 170a
170b

FIG. 9A

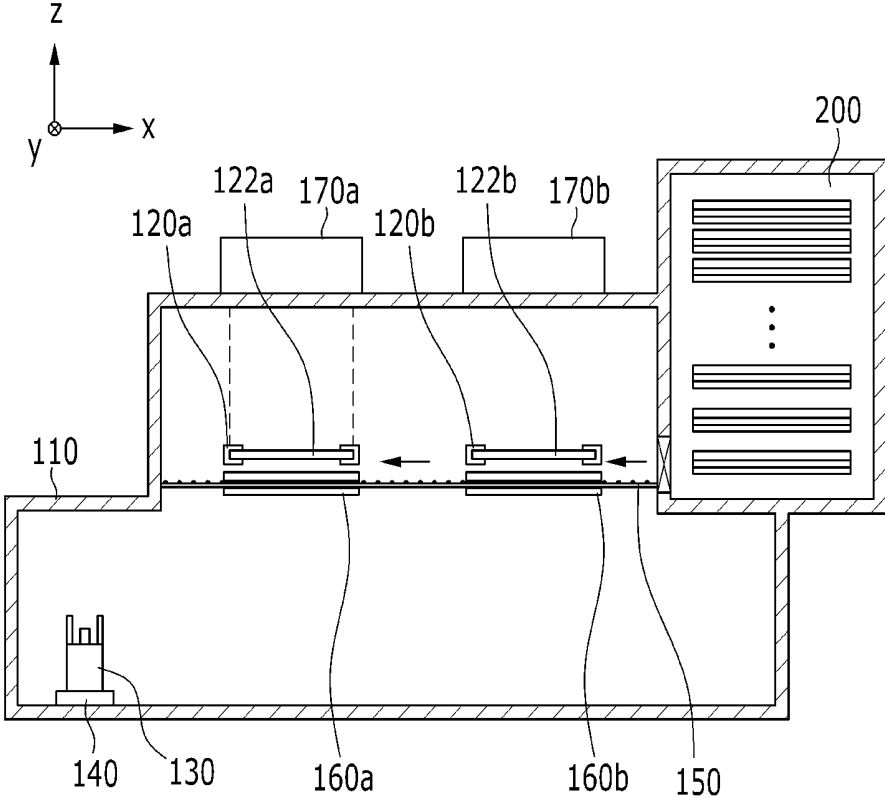

120 { 120a
120b

160 { 160a
160b

170 { 170a
170b

FIG. 9B

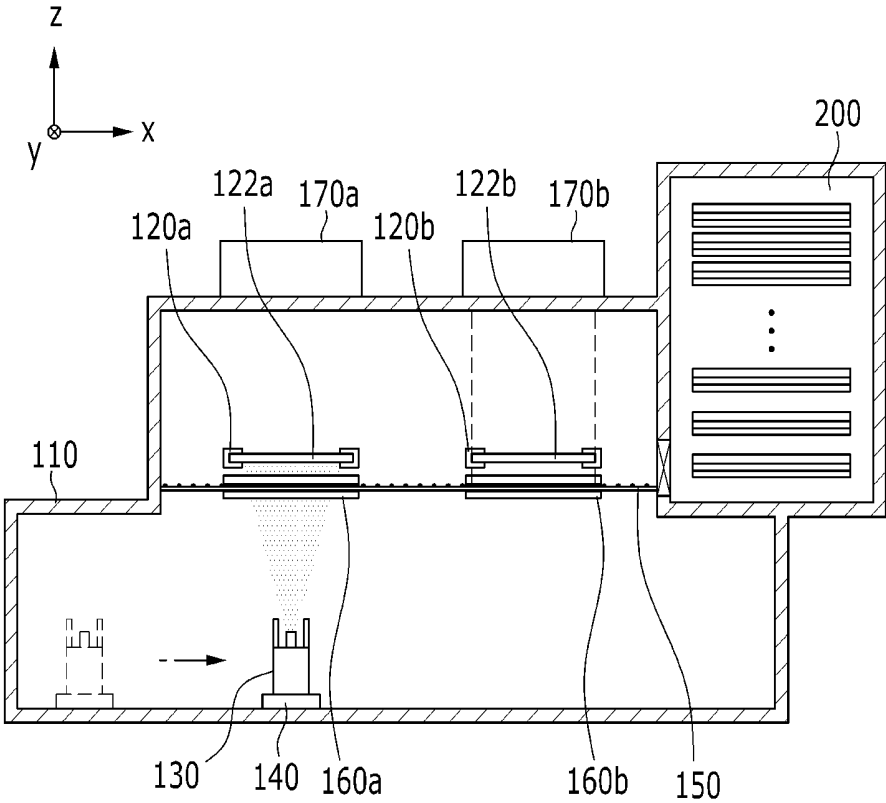

$120 \begin{cases} 120a \\ 120b \end{cases}$ $160 \begin{cases} 160a \\ 160b \end{cases}$ $170 \begin{cases} 170a \\ 170b \end{cases}$

FIG. 9C

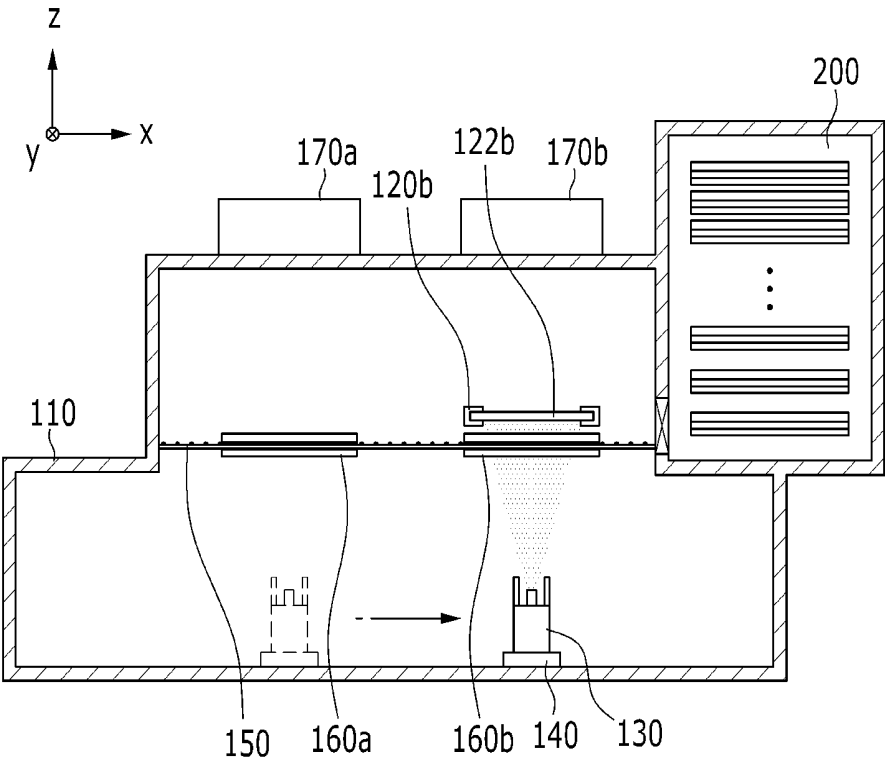

120 { 120a
120b

160 { 160a
160b

170 { 170a
170b

**DEPOSITION APPARATUS AND METHOD OF
MANUFACTURING ORGANIC LIGHT
EMITTING DIODE DISPLAY**

**CROSS-REFERENCE TO RELATED
APPLICATION**

[0001] This application claims priority to and the benefit of Korean Patent Application No. 10-2013-0046775 filed in the Korean Intellectual Property Office on Apr. 26, 2013, the entire contents of which are incorporated herein by reference.

BACKGROUND

[0002] (a) Field

[0003] The present disclosure relates to a deposition apparatus, a deposition system comprising the deposition apparatus and a method of manufacturing an organic light emitting diode display.

[0004] (b) Discussion of the Related Technology

[0005] An organic light emitting diode (OLED) display is a flat panel display which can be made lightweight and thin because it has a self-luminous characteristic and requires no separate light source. Particularly, the OLED display exhibits quality characteristics such as low power consumption, high luminance, high response speed, and as such, the OLED display receives much attention as a next-generation display device.

[0006] In general, an OLED display includes an organic light emitting element including an anode, an organic emission layer, and a cathode. Holes and electrons are injected from the anode and the cathode, respectively, to form excitons, and the excitons make a transition to a ground state, thereby causing the organic light emitting diode to emit light.

[0007] The anode and the cathode may be formed of a metal thin film or a transparent conductive thin film and the organic emission layer may be formed of at least one organic thin film. A vacuum deposition method may be used to form such an organic thin film, a metal thin film, and the like, on a substrate of the organic light emitting diode display. Generally, the vacuum deposition method is used for forming an organic thin film, a metal thin film, and the like. In a deposition device including a deposition source, a deposition material is inserted into a crucible and heated for deposition of the deposition material on the substrate such that a thin film is formed.

[0008] The above information disclosed in this Background section is only for enhancement of understanding of the background of the invention and therefore it may contain information that does not form the prior art.

SUMMARY

[0009] One aspect of the present invention provides a deposition apparatus that can process a plurality of substrates generally in parallel and minimize process standby time such as alignment of substrates and deposition masks and alignment time to achieve high productivity, and a deposition system including the same.

[0010] In addition, another aspect of the present invention provides a manufacturing method of an organic light emitting diode display using a deposition chamber and a deposition system.

[0011] A deposition apparatus according to an exemplary embodiment includes: a deposition chamber; a plurality of substrate holders comprising a first holder configured to maintain a substrate at a first substrate position in the depo-

sition chamber and a second holder configured to maintain another substrate at a second substrate position in the deposition chamber, a deposition source disposed in the deposition chamber and configured to supply a deposition material to apply onto substrates placed at the first and second substrate positions, and a deposition source transfer mechanism configured to move the deposition source to be opposite to one of the first and second substrates in a first direction, a substrate transfer mechanism configured to transfer a substrate in a second direction to or from the first substrate position and further configured to transfer another substrate in the second direction to or from the second substrate position.

[0012] The deposition chamber may further include a mask transfer mechanism configured to transfer at least one deposition mask to a first mask position disposed between the first substrate position and the first source position and a second mask position disposed between the second substrate position and the second source position.

[0013] The deposition chamber may further include a mask storing chamber attached to the deposition chamber and configured to store at least a deposition mask, and the mask storing chamber is connected with the mask transfer mechanism.

[0014] The mask transfer mechanism may be provided in one side end of the deposition chamber along the first direction and is configured to move a mask along the first direction between the mask storing chamber and the deposition chamber.

[0015] The deposition chamber may further include a mask cleansing chamber connected with the mask storing chamber and the deposition chamber and cleansing the deposition mask.

[0016] The mask cleansing chamber may be provided between the deposition chamber and the mask storing chamber.

[0017] The deposition chamber may further include an alignment device configured to align the respective substrates and the deposition masks.

[0018] The mask transfer mechanism may include a pair of rails extending in the first direction, the deposition mask comprises a mask main body that a shielding portion and an opening are formed and a frame supported by the rails by fixing the mask main body, and the frame of the deposition mask may further include a protection plate surrounding the rails.

[0019] A deposition system according to an exemplary embodiment includes a plurality of the deposition apparatus each of which comprises the deposition chamber, and a plurality of transfer chambers provided between and connect two immediately neighboring deposition chambers.

[0020] The deposition system may a mask transfer mechanism configured to transfer at least one mask to a first mask position disposed between the first substrate position and the first source position and to a second mask position disposed between the second substrate position and the second source position.

[0021] The deposition system may be configured to coordinate the substrate transfer mechanism and the mask transfer mechanism such that when a substrate is provided into the deposition chamber from the transfer chamber, the substrate is transferred along the second direction, and a deposition mask is transferred along the first direction that crosses the second direction.

[0022] The transfer chamber may accommodate the substrate transfer mechanism.

[0023] The deposition chamber may further include a buffer chamber connected to the transfer chamber. In this case, the substrate transfer portion may include a robot arm structure.

[0024] A manufacturing method of an organic light emitting diode display according to an exemplary embodiment includes: providing the deposition apparatus, transferring a first substrate and a second substrate independently into the deposition chamber to place the first substrate at the first substrate position and the second substrate at the second substrate position, providing a first deposition mask and a second deposition mask into the deposition chamber, aligning the first substrate and the first deposition mask at a first alignment location, transferring the deposition source to the first alignment location, applying a deposition material to the first substrate, aligning the second substrate and the second deposition mask at a second alignment location, transferring the deposition source to the second alignment location; and applying the deposition material to the second substrate.

[0025] The alignment to the second alignment location may be performed while the deposition material is applied to the first substrate.

[0026] The manufacturing method of the organic light emitting diode display may further include, after the spraying of the deposition material to the first substrate, discharging the first substrate from the deposition chamber.

[0027] A manufacturing method of an organic light emitting diode display according to another exemplary embodiment includes: providing the deposition apparatus, transferring a first substrate and a second substrate independently into the deposition chamber to place the first substrate at the first substrate position and the second substrate at the second substrate position, providing a first deposition mask and a second deposition mask into the deposition chamber, aligning the first substrate and the first deposition mask at a first alignment location, transferring the deposition source to the first alignment location, applying a deposition material to the first substrate, aligning the second substrate and the second deposition mask at a second alignment location, transferring the deposition source to the second alignment location; and applying the deposition material to the second substrate. While the deposition material is applied to the first substrate, the second substrate and the second mask are transferred to be aligned at the second alignment location. After the deposition material is applied to the first substrate, the first substrate is discharged from the deposition chamber.

[0028] The plurality of the deposition apparatuses may comprise first and second deposition apparatus, wherein the deposition materials used in the first and second deposition apparatuses are substantially different from each other.

[0029] The plurality of the deposition apparatuses may comprise first and second deposition apparatus, wherein the deposition mask used in the first deposition apparatus and the deposition mask used in the second deposition apparatus are substantially different from each other.

[0030] According to the exemplary embodiments of the present invention, a thin film process can be sequentially performed in a plurality of process lines provided in each of a plurality of deposition chambers through a single deposition source provided in each of the deposition chamber so that cost can be saved and productivity can be improved.

[0031] Further, standby time can be shortened by performing substrate transferring and substrate and mask alignment with respect to a substrate in a process line while a thin film deposition process is performed on a substrate in another process line, thereby further improving productivity.

BRIEF DESCRIPTION OF THE DRAWINGS

[0032] FIG. 1 is a top plan view of a deposition system according to a first exemplary embodiment.

[0033] FIG. 2 is a schematic side view of a deposition chamber of the deposition system according to the first exemplary embodiment.

[0034] FIG. 3 is a partially enlarged view of the deposition chamber of the deposition system according to the first exemplary embodiment.

[0035] FIG. 4 is a partial enlarged view of the deposition system according to the first exemplary embodiment.

[0036] FIG. 5 and FIG. 6 are top plan views of a substrate transfer portion of the deposition system according to the first exemplary embodiment.

[0037] FIG. 7 is a top plan view of a deposition system according to a second exemplary embodiment.

[0038] FIG. 8 is a schematic side view of a deposition chamber of a deposition system according to a third exemplary embodiment.

[0039] FIG. 9A to FIG. 9C are schematic diagrams of a manufacturing method of an organic light emitting diode (OLED) display according to an exemplary embodiment.

DETAILED DESCRIPTION OF THE EMBODIMENTS

[0040] Hereinafter, a deposition chamber, a deposition system including the deposition chamber, and a manufacturing method of an organic light emitting diode display will be described in further detail with reference to the accompanying drawings. However, the present invention is not limited to the exemplary embodiments disclosed hereinafter but has many variations, and the exemplary embodiments described hereinafter are provided to make the disclosure of the present invention complete and to completely inform a person of ordinary skill in the art the scope of the present invention. In the drawings, like reference numerals refer to like elements.

[0041] In addition, unless explicitly described to the contrary, the word "comprise" and variations such as "comprises" or "comprising", will be understood to imply the inclusion of stated elements but not the exclusion of any other elements. Further, the word "on" means positioning on or below the object portion, but does not essentially mean positioning on the upper side of the object portion based on a gravity direction.

[0042] In order to form an organic thin film, a metal thin film, and the like using the vacuum deposition method, a deposition system such as a cluster-type deposition system, an inline deposition system, and the like may be used. The inline deposition system is a deposition system in which a substrate loading chamber, a substrate unloading chamber, and a plurality of deposition chambers disposed between the substrate loading chamber and the substrate unloading chamber are arranged in a row, and has a merit of shortening a process time compared to the cluster-type deposition system.

[0043] FIG. 1 is a top plan view of a deposition system according to a first exemplary embodiment, FIG. 2 is a schematic side view of a deposition chamber according to the first

exemplary embodiment, and FIG. 3 is a partial exploded perspective view of the deposition chamber according to the first exemplary embodiment.

[0044] Referring to FIG. 1, a deposition system according to the first exemplary embodiment includes a plurality of deposition chambers 100 and a plurality of transfer chambers 300.

[0045] The deposition chamber 100 is a means for forming a thin film of a substrate 122, and is provided in plural corresponding to the number of thin films formed on the substrate 122.

[0046] For example, when a display device formed on the substrate 122 is an organic light emitting diode (OLED) display, an emission layer ELM is formed, and a hole injection layer (HIL), a hole transport layer (HTL), an electron transporting layer ETL, and an electron injection layer may be further formed. In addition, a metal thin film functioning as a cathode or an anode or a transparent conductive thin film may be further formed on the substrate 122. The thin films are formed in different deposition chambers 100, and therefore the number of the deposition chambers 100 according to the present exemplary embodiment corresponds to the number of an organic thin film, a metal thin film, and the like.

[0047] Referring to FIG. 2, each of the deposition chambers 100 includes a chamber main body 110, a substrate fixing portion 120, a deposition source 130, a deposition source transfer portion 140, and a mask transfer portion 150.

[0048] The chamber main body 110 defines an inner space formed therein, and performs a process for forming a thin film on the substrate 122 in the space. A vacuum pump (not shown) that decreases an internal pressure by discharging gas from the space and a venting means (not shown) that increases the internal pressure in the chamber main body by injecting a constant gas to the inner space of the chamber main body may further be provided.

[0049] The substrate 122 (122a, 122b) is transferred into the inner space of the chamber main body 110 and fixed to be opposite to a spray nozzle of the deposition source 130 by the substrate fixing portion 120 (120a and 120b). A process and structure for carrying the substrate 122 into the inner space of the chamber main body 110 and discharging the substrate 122 from the chamber main body 100 will be described later.

[0050] The substrate fixing portion or substrate holder 120 has a structure for easily attaching and detaching the substrate 112 so as to stably fix the substrate 122 while a thin film of a deposition material is formed and then discharge the substrate 122 from the inner space of the chamber main body 110 after termination of the treatment.

[0051] The substrate fixing portions 120a and 120b are provided in plural to treat a plurality of substrates in the deposition chamber 100 during one deposition process. The plurality of substrate fixing portions 120a and 120b respectively fix or hold the plurality of substrates 122a and 122b and can maintain the substrates at their deposition stations. In embodiments, the substrate holders 120a and 120b may be fixed in the deposition stations. In alternative embodiments, the substrate holders 120a and 120b may be movable to transfer substrates to the deposition stations and stop at the deposition stations to maintain the transferred substrates at the deposition stations.

[0052] In the present exemplary embodiment, the substrate fixing portion 120 is exemplarily formed of two fixing portions, i.e., the first substrate fixing portion 120a and the second substrate fixing portion 120b, but it is not restrictive. The

first substrate fixing portion 120a and the second substrate fixing portion 120b fix the first substrate 122a and the second substrate 122b, respectively corresponding thereto. And the first substrate fixing portion 120a and the second substrate fixing portion 120b may be disposed generally in parallel with each other and arranged along a first direction (i.e., x-axis direction) for the respective substrates 122a and 122b to be opposite to the deposition source 130.

[0053] In addition, during a deposition process with respect to the substrates 122a and 122b, the first substrate fixing portion 120a and the second substrate fixing portion 120b may be disposed at a distance from each other, interposing a gap therebetween along the first direction so as to prevent the deposition material from being attached to the second substrate that is waiting for deposition while depositing the first substrate.

[0054] Referring to FIG. 3, as a means for discharging a deposition material for deposition to the substrate 122, the deposition source 130 is provided with a space (not shown) for containing a deposition material such as an organic material, and spray nozzles 134 spraying the deposition material are formed in one side of the deposition source 130, disposed opposite to the substrate 120.

[0055] The deposition material containing space may be formed of a ceramic material having an excellent heat emission feature, such as alumina (Al₂O₃), aluminum nitride (AlN), and the like, and it is not restrictive. The deposition material receiving space may be formed of various materials having excellent heat emission feature and heat resistance.

[0056] Heater (not shown) may be formed to surround the external surface of the deposition material containing space in a closely attached manner, and the heater heats the received deposition material for vaporization of the deposition material.

[0057] As shown in FIG. 3, the deposition source 130 may be provided as a linear deposition source extended in a second direction (i.e., y-axis direction) that crosses the first direction. In embodiments, the x-axis direction and the y-axis direction are generally perpendicular to each other. In this case, the linear deposition source may be extended corresponding to the length of the substrate opposite thereto.

[0058] An angle control member 136 that controls or limits a spray angle of the deposition material may be formed at the periphery area of the spray nozzles 134. As shown in FIG. 3, the angle control member 136 is extended along a length direction of the linear deposition source 130 to make the organic material uniformly sprayed on the substrate 30 by controlling a deposition angle of the deposition material sprayed from the spray nozzles 134, and prevents the deposition material from being attached to other substrate that does not experience a deposition process during the deposition process.

[0059] As a means for transferring the deposition source 130, the deposition source transfer portion or deposition source transfer mechanism 140 moves the deposition source 130 to be opposite to one of the substrates 122a and 122b. The deposition source transfer portion 140 enables a single deposition source 130 to be sequentially deposited to the plurality of substrates 122a and 122b.

[0060] When the deposition process is performed to the first substrate 122a, the deposition source 130 is disposed at a location that is opposite to the first substrate 122a through the deposition source transfer portion 140. When the deposition process for the first substrate 122a is finished, the deposition

source **130** is disposed at a location that is opposite to the second substrate **122b** through the deposition source transfer portion **140** for performance of the deposition process.

[0061] A plurality of deposition masks **160** includes two deposition masks **160a** and **160b**, and is provided as a means for forming patterns of an organic thin film on the substrate **122**. In a deposition mask, openings are formed between shielding portions that block deposition of the organic material such that the organic material is deposited on the substrate **122** through the openings.

[0062] The deposition mask **160** is disposed under one surface of the substrate **122**, to which the pattern of the organic thin film is to be formed. In the present exemplary embodiment, the deposition process is performed with respect to two substrates **122** in one chamber, and therefore two deposition masks **160a** and **160b** are used.

[0063] The two deposition masks **160a** and **160b** are transferred and placed to correspond to the substrates **122a** and **122b** by the mask transfer portion or mask transfer mechanism **150**. As a means for arranging the deposition masks **160a** and **160b** at mask locations respectively corresponding to the substrates **122a** and **122b**, the mask transfer portion **150** may transfer the deposition masks **160a** and **160b** generally in parallel with the first direction (x-axis direction).

[0064] The mask transfer portion **150** includes a pair of rails **152** extending in the first direction (x-axis direction) as shown in FIG. 3 separated from a distance with a predetermined gap along the second direction (y-axis direction) and a plurality of rollers **154** arranged along a length direction of the pair of rails **152** and contacting the deposition mask.

[0065] When the deposition mask **160** is being transferred, friction between the deposition mask **160** and the rail **152** is reduced by the rollers **154** so that the deposition mask **160** can be smoothly transferred.

[0066] In this case, the deposition mask **160** is disposed between the pair of rails **152**. And the deposition mask **160** includes a mask main body **162** where the shielding portion and the openings are formed and a frame **164** fixing the mask main body **162** and supported by the rails **152**.

[0067] The deposition mask **160** may further include a protection plate **166** extending from one side of the frame **164** to prevent the deposition material from being attached to the rails **152**. That is, the protection plate **166** is extended from a side opposite to the spray nozzles **134** to cover the rail **152**.

[0068] In the present exemplary embodiment, the mask transfer portion **150** is illustrated as a rail, but it is not restrictive. The mask transfer portion **160** may have various shapes as long as the deposition mask **160** is transferred to one direction and arranged at a predetermined location. In addition, the deposition mask **160** may have various shapes as long as it is being supported by the mask transfer portion **150** and transferred along the mask transfer portion **150**.

[0069] Referring back to FIG. 2, a mask storing chamber or mask storage **200** may further be included to store the deposition mask **160** at one side of the chamber main body **110**. The mask storing chamber **200** stores a required deposition mask **160** according to the type of an organic thin film, a metal thin film, and the like formed in each deposition chamber **100**, and discharges the deposition mask **160** toward the inner space of the chamber main body **110** during the deposition process.

[0070] The mask storing chamber **200** is connected with the mask transfer portion **150** to mount the deposition mask **160** discharged from the mask storing chamber **200** to the mask transfer portion **150**.

[0071] In this case, the deposition mask **160** may be mounted to the mask transfer portion **150** using a mask transfer holder (not shown).

[0072] In order to arrange the substrates **122a** and **122b** and the deposition masks **160a** and **160b** at predetermined locations, respectively, a first alignment portion **170a** and a second alignment portion **170b** may be formed at one side of the chamber main body **110**. The first alignment portion **170a** aligns the first substrate **122a** and the first deposition mask **160a**, and the second alignment portion **170b** aligns the second substrate **122b** and the second deposition mask **160b**.

[0073] FIG. 4 is a partially exploded side view of the deposition chamber according to the first exemplary embodiment.

[0074] The mask storing chamber **200** is connected with the mask transfer portion **150** to make the deposition mask **160** transferred from the inner space of the chamber main body **110** into the mask storing chamber **200** through the mask transfer portion **150** after the deposition process is finished. In addition, the deposition mask **160** stored in the mask storing chamber **200** is carried into the deposition mask **160** again for a deposition process.

[0075] As shown in FIG. 1, the deposition system according to the exemplary embodiment includes a plurality of deposition chambers **100** and a plurality of transfer chambers **300** disposed between the deposition chambers **100** to connect neighboring deposition chambers **100**.

[0076] In embodiments, the substrates **122** are provided by being transferred along a direction (for example, y-axis direction) to which the deposition chambers **100** and the transfer chambers **300** are connected, and the deposition mask **160** may be provided along another direction (for example, x-axis direction) that crosses the transfer direction of the substrate **122**.

[0077] As shown in FIG. 1, when the deposition chamber **100** and the transfer chamber **300** are arranged in a row along the second direction (y-axis direction), the substrate **122** may be transferred along the alignment direction of the chambers. When the two substrates **122a** and **122b** are processed in a single deposition chamber **100**, the two substrates **122a** and **122b** may be provided generally in parallel with the chamber alignment direction (refer to AL and BL of FIG. 1).

[0078] FIG. 5 and FIG. 6 are top plan views illustrating exemplary variations of the substrate transfer portion according to the first exemplary embodiment.

[0079] The transfer chamber **300** includes a substrate transfer portion or substrate transfer mechanism **310a** that discharges the substrate **122** from an adjacent deposition chamber and carries the discharged substrate **122** into another deposition chamber. As shown in FIG. 5, the substrate transfer portion **310a** may be formed in the shape of a robot arm. The robot arm is inserted in a deposition chamber **1001** where the deposition process is finished and grips the substrate **122**, and then mounts the gripped substrate **122** in a substrate fixing portion **120** in another adjacent deposition chamber **1002** where the next deposition process is going to be performed.

[0080] In addition, as shown in FIG. 6, the substrate transfer portion **310** may be formed using a sliding method. And the substrate transfer portion **310** includes a substrate tray **312** on which the substrate **122** is mounted or placed and a sliding

guide 314 along which the substrate tray 312 is slid. After the substrate tray 312 is inserted in the deposition chamber 1001 where the deposition process is finished and then the substrate 122 is mounted on the substrate tray 312, the substrate 122 is mounted to a substrate fixing portion 120 in another adjacent deposition chamber 1002 where the next deposition process is going to be performed.

[0081] In addition, the deposition system according to the exemplary embodiment may further include a loading chamber 400 and a substrate unloading chamber 500. The substrate 122 is loaded into the deposition system through the substrate loading chamber 400, and a deposition material is deposited in each of the deposition chamber 100 to form an organic thin film on the substrate 122, and then the substrate 122 is unloaded through the substrate unloading chamber 500.

[0082] A gate valve may be provided between the substrate loading chamber 400 and the deposition chamber 100, and another gate valve may be provided between the deposition chamber 100 and the substrate unloading chamber 500. Each gate valve is provided between one of the deposition chambers 100 and the immediately neighboring transfer chamber 200. Such a gate valve is opened while the substrate 122 is being transferred and closed while the organic material deposition process is performed such that the organic material deposition process can be performed in a vacuum state.

[0083] FIG. 7 is a top plan view of a deposition system according to a second exemplary embodiment.

[0084] Referring to FIG. 7, a deposition system according to the present exemplary embodiment further includes a buffer chamber 320 connected with a transfer chamber 300 at one side of the transfer chamber 300. When the substrate 122 is damaged or a problem occurs in a deposition chamber 100 or a transfer chamber 300, the substrate 122 may be transferred into the buffer chamber 320 and then stored.

[0085] The buffer chamber 320 is provided in connection with the transfer chamber 300 at a location that is spaced apart from a transfer path of the substrate 122 in order not to interrupt transferring of the substrate 122. When the substrate transfer portion 310 of the transfer chamber 300 is provided in the shape of a robot arm, the buffer chamber 320 is provided adjacent to the substrate transfer portion 310 formed in the shape of the robot arm to temporarily store the substrate, and accordingly, a time loss that may occur during mass production can be reduced.

[0086] In the deposition system according to the present exemplary embodiment, other configuration than the buffer chamber 320 may be the same as that of the first exemplary embodiment.

[0087] FIG. 8 is a schematic side view of a deposition chamber of a deposition system according to a third exemplary embodiment.

[0088] Referring to FIG. 8, in a deposition system according to the present exemplary embodiment, a mask cleansing chamber 210 connected with a mask storing chamber 200 and the inside of a chamber main body 110 and cleaning a deposition mask 160 is formed in a lower end portion of the mask storing chamber 200.

[0089] The mask cleaning chamber 210 is a device for cleaning a deposition material attached to a deposition mask after the deposition mask 160 repeats the deposition process several times, and may clean the deposition mask 160 using plasma or ultraviolet (UV) ray.

[0090] Gate valves are respectively provided between the mask storing chamber 200 and the chamber main body 110,

between the mask cleaning chamber 210 and the chamber main body 110, and between the mask storing chamber 200 and the mask cleaning chamber 210, and the gate valves are opened when the deposition mask 160 is transferred along the mask transfer portion 150 and the gate valves are closed when the transferring of the deposition mask 160 is finished.

[0091] The mask cleaning chamber 210 is connected with the mask transfer portion 150 and thus the deposition mask 160 transferred from the inner space of the chamber main body 110 after the deposition process can be carried into the mask cleansing chamber 210 through the mask transfer portion 150. In addition, the deposition mask 160 cleaned in the mask cleaning chamber 210 is carried back into the inner space of the chamber main body 110 for the next deposition process.

[0092] The mask transfer portion 150 may be moved so as to be connected with the mask storing chamber 200 or the mask cleaning chamber 210. For example, in FIG. 8, the mask transfer portion 150 is illustrated to be connected with the mask cleaning chamber 210, but the mask transfer portion 150 may be connected with the mask storing chamber 200 by being transferred upward.

[0093] In the deposition system according to the present exemplary embodiment, a structure, excluding the structure related to the mask cleansing chamber 210 is the same as that of the first exemplary embodiment, and a buffer chamber may be provided as in the second exemplary embodiment.

[0094] Hereinafter, the operation and the manufacturing method will be described by illustrating the deposition system according to the first exemplary embodiment, but a deposition system according to the second or third exemplary embodiment or a deposition system according to the exemplary variations may also be applicable.

[0095] FIG. 9A to FIG. 9C are schematic diagrams sequentially illustrating a manufacturing method of an OLED display according to an exemplary embodiment.

[0096] Referring to the drawing, the manufacturing method of the OLED display according to the exemplary embodiment includes providing a deposition source, placing a mask, aligning a first substrate, transferring the deposition source, depositing the first substrate, aligning a second substrate, transferring the deposition source, and depositing the second substrate.

[0097] First, as shown in FIG. 9A, the deposition source 130 spraying the deposition material is provided in the deposition chamber 100. The first substrate 122a is inserted into the deposition chamber 100. The second substrate 122b is inserted into the deposition chamber 100 independently from the transfer of the first substrate 122a. In embodiments, the second substrate 122b can be inserted into the deposition chamber 100 while depositing the first substrate 122a.

[0098] The first substrate 122a and the second substrate 122b are inserted generally in parallel along the second direction (y-axis direction) where the deposition chamber 100 and the transfer chamber 300 are arranged (refer to AL and BL of FIG. 1). The first substrate 122a and the second substrate 122b can be arranged generally in parallel with each other, interposing a gap therebetween along the first direction that crosses the transfer direction of the first substrate 122a and the second substrate 122b.

[0099] The first deposition mask 160a and the second deposition mask 160b are transferred into the deposition chamber 100. The deposition masks 160a and 160b received in the mask storing chamber 200 are discharged and mounted on the

mask transfer portion **150**, and then the deposition masks **160a** and **160b** are transferred to predetermined locations.

[0100] That is, the first deposition mask **160a** is transferred to a location corresponding to the first substrate **122a**, and the second deposition mask **160b** is transferred to a location corresponding to the second substrate **122b**. The first substrate **122a** and the first deposition mask **160a** are aligned in a predetermined first alignment location through a first alignment portion **170a**. In embodiments, the first deposition mask **160a** and the second deposition mask **160b** are transferred into the deposition chamber **100** before the first and second substrates are transferred into the chamber **100**, respectively. Alternatively, the first deposition mask **160a** and the second deposition mask **160b** are transferred into the deposition chamber **100** after the first and second substrates are transferred into the chamber **100**, respectively.

[0101] The deposition source **130** is transferred to the first alignment location, and then as shown in FIG. 9B, the deposition material received in the receiving space of the deposition source **130** is heated to be vaporized and then sprayed toward the first substrate **122a**.

[0102] The second substrate **122b** and the second deposition mask **160b** are aligned in a predetermined second alignment location through the second alignment portion **170b**. The aligning of the second substrate **122b** and the second deposition mask **160b** in the second alignment location may be performed while the deposition material is sprayed to the first substrate **122a**. Since the second substrate **122b** is aligned while the deposition material is sprayed to the first substrate **122a**, a process time can be shortened.

[0103] When the deposition process with respect to the first substrate **122a** is finished, as shown in FIG. 9, the deposition source **130** is transferred to the second alignment location and then the deposition material is sprayed toward the second substrate **122b**.

[0104] After the deposition process with respect to the first substrate **122a** is finished and before a deposition process with respect to the second substrate **122b** starts, the first substrate **122b** may be discharged to the outside of the deposition chamber **100**. During the deposition process with respect to the second substrate **122b**, the first substrate **122a** may be prepared for the next deposition process by being transferred to the next deposition chamber through the transfer chamber **300**. Accordingly, a process time can be shortened.

[0105] After the deposition process with respect to the second substrate **122b** is finished, the second substrate **122b** may also be prepared for the next process by being transferred to the next deposition chamber. Through performing deposition steps of the above-stated deposition process in each deposition chamber, a multi-layered organic thin film may be formed in the substrates **122a** and **122b**.

[0106] While this invention has been described in connection with what is presently considered to be practical exemplary embodiments, it is to be understood that the invention is not limited to the disclosed embodiments, but, on the contrary, is intended to cover various modifications and equivalent arrangements included within the spirit and scope of the appended claims.

What is claimed is:

1. A deposition apparatus comprising:

a deposition chamber;

a plurality of substrate holders comprising a first holder configured to maintain a substrate at a first substrate

position in the deposition chamber and a second holder configured to maintain another substrate at a second substrate position in the deposition chamber;

a deposition source disposed in the deposition chamber and configured to supply a deposition material to apply onto substrates placed at the first and second substrate positions; and

a deposition source transfer mechanism configured to move the deposition source to be opposite to one of the first and second substrates in a first direction;

a substrate transfer mechanism configured to transfer a substrate in a second direction to or from the first substrate position and further configured to transfer another substrate in the second direction to or from the second substrate position.

2. A method of manufacturing an organic light emitting diode (OLED) display, the method comprising:

providing the deposition apparatus of claim 1,

transferring a first substrate and a second substrate independently into the deposition chamber to place the first substrate at the first substrate position and the second substrate at the second substrate position;

providing a first deposition mask and a second deposition mask into the deposition chamber;

aligning the first substrate and the first deposition mask at a first alignment location;

transferring the deposition source to the first alignment location;

applying a deposition material to the first substrate;

aligning the second substrate and the second deposition mask at a second alignment location;

transferring the deposition source to the second alignment location; and

applying the deposition material to the second substrate.

3. The method of claim 2, wherein the second substrate and the second mask are transferred to be aligned at the second alignment location while the deposition material is applied to the first substrate.

4. The method of claim 2, further comprising, after the applying the deposition material to the first substrate, discharging the first substrate from the deposition chamber.

5. A method of manufacturing an organic light emitting diode (OLED) display, the method comprising:

providing a plurality of the deposition apparatuses of claim 1 to be connected to each other,

wherein, for each of the deposition apparatuses, the method comprises,

transferring a first substrate and a second substrate independently into the deposition chamber to place the first substrate at the first substrate position and the second substrate at the second substrate position;

providing a first deposition mask and a second deposition mask into the deposition chamber;

aligning the first substrate and the first deposition mask at a first alignment location;

transferring the deposition source to the first alignment location;

applying a deposition material to the first substrate;

aligning the second substrate and the second deposition mask at a second alignment location;

transferring the deposition source to the second alignment location; and

applying the deposition material to the second substrate,

wherein while the deposition material is applied to the first substrate, the second substrate and the second mask are transferred to be aligned at the second alignment location,

wherein after the deposition material is applied to the first substrate, the first substrate is discharged from the deposition chamber.

6. The method of claim 5, wherein the plurality of the deposition apparatuses comprises first and second deposition apparatus, wherein the deposition materials used in the first and second deposition apparatuses are substantially different from each other.

7. The method of claim 5, wherein the plurality of the deposition apparatuses comprises first and second deposition apparatus, wherein the deposition mask used in the first deposition apparatus and the deposition mask used in the second deposition apparatus are substantially different from each other.

* * * * *

专利名称(译)	沉积设备和制造有机发光二极管显示器的方法		
公开(公告)号	US20140322852A1	公开(公告)日	2014-10-30
申请号	US14/074629	申请日	2013-11-07
[标]申请(专利权)人(译)	三星显示有限公司		
申请(专利权)人(译)	三星DISPLAY CO., LTD.		
当前申请(专利权)人(译)	三星DISPLAY CO., LTD.		
[标]发明人	JOO SUNG JOONG CHA YOU MIN PARK SEUK HWAN		
发明人	JOO, SUNG-JOONG CHA, YOU-MIN PARK, SEUK-HWAN		
IPC分类号	H01L51/00		
CPC分类号	H01L51/0012 C23C14/50 C23C14/568 H01L51/0011 H01L51/56		
优先权	1020130046775 2013-04-26 KR		
其他公开文献	US9267202		
外部链接	Espacenet USPTO		

摘要(译)

一种沉积设备，包括沉积室，多个基板保持器，包括：第一保持器，被配置为将基板保持在沉积室中的第一基板位置；以及第二保持器，被配置为将另一基板保持在沉积室中的第二基板位置，沉积源，设置在沉积室中并配置成供应沉积材料以施加到放置在第一和第二基板位置的基板上；以及沉积源转移机构，配置成使沉积源移动到与第一和第二基板位置中的一个相对在第一方向上的基板，基板传送机构，被配置为沿第二方向将基板传送到第一基板位置或从第一基板位置传送基板，并且还被配置为沿第二方向将另一基板传送到第二基板位置或从第二基板位置传送另一基板

